

中原大學 95 學年度碩士班入學考試

3 月 18 日 16:00~17:30 土木工程系水環組

誠實是我們珍視的美德，
我們喜愛「拒絕作弊，堅守正直」的你！

科目：水文學及流體力學

(共 3 頁第 1 頁)

可使用計算機，惟僅限不具可程式及多重記憶者

不可使用計算機

一、Select the correct answer. (30%)

(1) Surface tension has the dimensions (F: force, L: length)

- (a) F (b) FL^{-1} (c) FL^{-2} (d) FL^{-3} (e) none of these answers.

(2) The differential equation for pressure variation in a static fluid may be written

(y: measured vertically upward, γ : specific weight, p : pressure, ρ : density).

- (a) $dp = -\gamma dy$ (b) $d\rho = -\gamma dy$ (c) $dy = -\rho dp$ (d) $dp = -\rho dy$ (e) $dp = -y d\rho$

(3) The pressure center is

- (a) at the centroid of the submerged area
(b) below centroid of the pressure prism
(c) independent of the orientation of the area
(d) a point on the line of action of the resultant force
(e) always above the centroid of the area

(4) The Kinetic-energy correction factor (v : velocity, V : average velocity, A : area)

- (a) applies to the continuity equation (b) has the units of velocity head

(c) is expressed by $\frac{1}{A} \int_A \left(\frac{v}{V}\right) dA$ (d) is expressed by $\frac{1}{A} \int_A \left(\frac{v}{V}\right)^2 dA$

(e) is expressed by $\frac{1}{A} \int_A \left(\frac{v}{V}\right)^3 dA$

(5) The shear stress in a fluid flowing between two fixed parallel plates

- (a) is constant over the cross section
(b) is zero at the plates and increases linearly to the mid-point
(c) varies parabolically across the section
(d) is zero at the midplane and varies linearly with distance from the midplane
(e) is none of these answers

(6) In irrotational flow of an ideal fluid

- (a) a velocity potential exists (b) all particles must move in straight lines
(c) the motion must be uniform (d) the flow is always steady
(e) the velocity must be zero at a boundary

(7) A static tube is used to measure

- (a) the pressure in a static fluid (b) the velocity in a flowing stream
(c) the total pressure (d) the dynamic pressure (e) the undisturbed fluid pressure

(8) Cavitation is caused by

- (a) low barometric pressure (b) high pressure (c) low pressure
(d) low velocity (e) hot water

(9) Critical depth in a nonrectangular channel is expressed by

(Q: discharge, T: water surface width, A: cross-section area)

- (a) $\frac{Q^2 T}{g A^3} = 1$ (b) $\frac{Q T^2}{g A^2} = 1$ (c) $\frac{Q^2 A^3}{g T^2} = 1$ (d) $\frac{Q^2}{g A^3} = 1$ (e) none of these answers.

(10) In open-channel flow

- (a) the hydraulic grade line is always parallel to the energy grade line
(b) the energy grade line coincides with the free surface
(c) the energy and hydraulic grade lines coincide
(d) the hydraulic grade line can never rise
(e) the hydraulic grade line and free surface coincide

二、 In fig.2, water discharge from a two-dimensional slot as indicated at A into the air. At B water discharges from under a gate onto a floor. Neglecting all losses, determine the discharge of A and at B per foot of width. (10%)

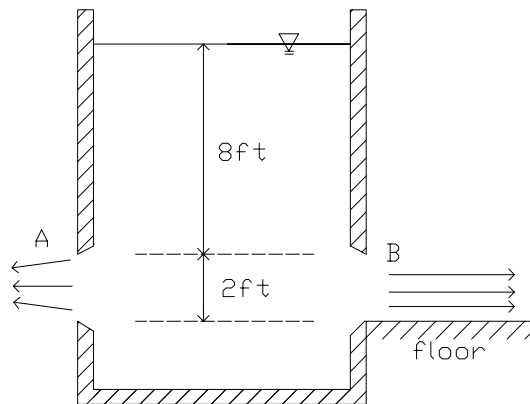

Fig.2

三、 Please design an equipment to verify the momentum equation. (10%)

四、 A 30-cm diameter well installed in confined aquifer. The aquifer has a saturated thickness of 15 m, hydraulic conductivity of 10 m/day and coefficient of storage is 0.0001. The radius of influence for the well is 1,000 m. (15%)

- (a) If the allowable drawdown at the well is limited to 5.0 m. Determine the maximum steady-state pumping rate in m^3/day . (Neglect the well resistance)
(b) Determine the drawdown at the well and 30 m from the well after pumping $100 \text{ m}^3/\text{day}$ for 3 hours.

五、 The 6-hour unit hydrograph for a watershed is given below. (25%)

Time (h)	0	6	12	18	24	30	36	42
U(6,t) (m ³ /sec-cm)	0	2	32	88	42	15	4	0

- (a) Determine the drainage area in km².
- (b) For a storm over the watershed having rainfall of 5 cm for the first 6 hours and 15 cm for the second 6 hours, compute the streamflow hydrograph, assuming constant base flow of 10 m³/sec and Infiltration index $\phi = 0.2$ cm/hours.
- (c) Compute the S-hydrograph.

六、 What is the probability that a 10-year flood will occur (a) in the next year, (b) at least once during the next 5 years, and (c) only twice during the next 10 years. (10%)